

ISOVER HygroWick

– Insulation of pipes against condensation





Table of contents

Insulation of pipes against condensation

- Traditional solutions page 03
- The HygroWick Systemet page 03

Final surface

- The simplest solution page 04
- A neater finish page 04
- Finish without any holes page 04

Installation of HygroWick

- Corrosion protection page 05
- Instalation of the insulation page 05
- For PVC film without holes

Detaljer

- Pipebends page 06
- Vertical pipes page 06
- Valves and flanges page 06
- Penetration page 07
- Horizontal termination page 07
- Supports and stops page 07
- Space requirements page 07

Insulation of pipes against condensation

In addition to insulation to prevent unnecessary energy consumption, cold pipes, that is pipes whose media temperature is lower than that of the surroundings, must be insulated to prevent condensation.

The insulation must be installed both to prevent condensation on the outside of the insulation, which can be harmful to the surroundings, and ingress of moisture, which can condense and accumulate around the cold pipe, impairing the performance of the insulation over time.

Traditional solutions

The problem has traditionally been resolved in two ways.

- either by insulating with mineral wool, protected on the outside by a vapour-proof layer, typically aluminium foil with taped joints;
- or by insulating with a highly diffusion-proof material such as elastomeric foam products.

Both solutions are vulnerable to damage and defective installation.

Experience shows that it is difficult to ensure a 100% airtight vapour seal around joints with valves, supports and other penetrations. There is also a high risk that the vapour seal will suffer minor damage during the lifetime of the pipework.

For systems based on highly damp-proof elastomeric insulation materials, the vulnerable point is the glued joints which tend to open over time.

Unwanted moisture seeping in through openings in the damp-proof layer is forced inwards as a result of the vapour pressure gradient between the warm surroundings and the cold pipe. When the moisture cools down enough, it will condense and form a layer of water on the surface of the pipe.

As outward vapour pressure never arises, the water accumulates around the pipe over time.

The HygroWick system

The HygroWick system breaks with the traditional thought process, and is instead built up so that it can transport the moisture away from the pipe and let it evaporate to the surrounding air.

This effect is achieved by using a moisture-absorbent wicking material between the insulation and pipe, which is led out to the surrounding air through a groove in the insulation.

The wick draws the water to the outside of the insulation, from which it evaporates as it is warmed by the higher temperature of the surroundings.

Moisture will only be able to diffuse through the wicking slot if the wick is completely dry. When the wick is even slightly moist, the higher vapour pressure in the external part of the wick (in relation to the surroundings) will ensure that moisture movement is outwards. The wicking effect transports the water out several times faster than new moisture can seep in, even with a slightly damaged vapour seal.

This ensures that there is always a dry environment around the surface of the pipe.

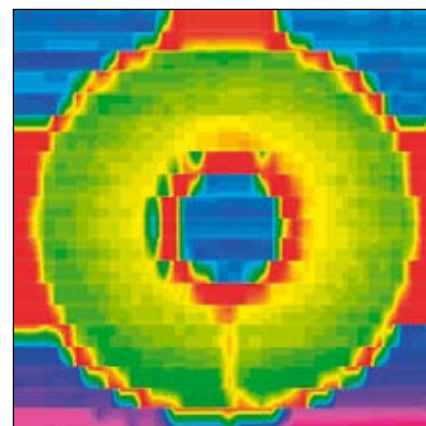

The X-ray image shows a cross-section of an experimental HygroWick installation. It is clear that the moisture is taken up by the wicking material and transported through the slit (at the bottom), while the insulation remains dry.

Red: Moisture or steel/aluminium, Green: Dry
Blue: Air, Yellow: Hygroscopic moisture.

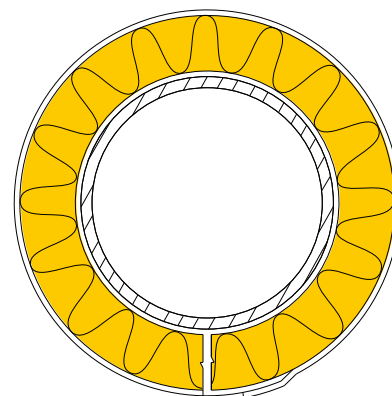

HygroWick princippet

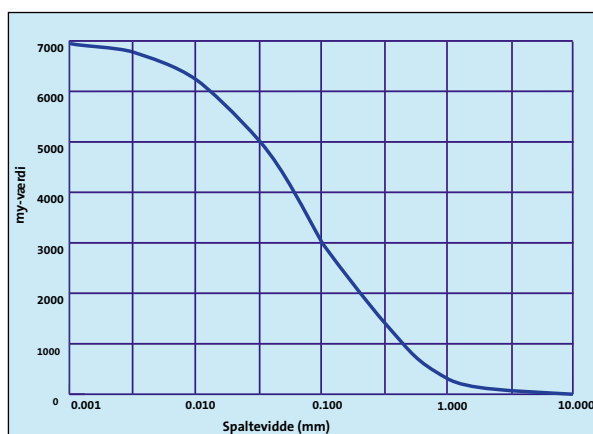

Even minor inaccuracies can impact significantly on function. The curve shows how even quite small cracks in the bond of cellular rubber products have a significant effect on the tightness of the insulation, defined by the μ -value. Note that the μ -value is more than halved by a 0.1mm crack.



Final surface

The water transported out via the slot in the insulation must be able to evaporate from the wick.

Therefore, the final surface must not be too impermeable. This can be ensured in several ways.

The simplest solution

1. On pipes concealed above suspended ceilings or in service shafts, the aluminium foil surface of the insulation can be the finish. Circumferential joints are sealed with aluminium tape. Longitudinal joints are turned downwards and are not taped.

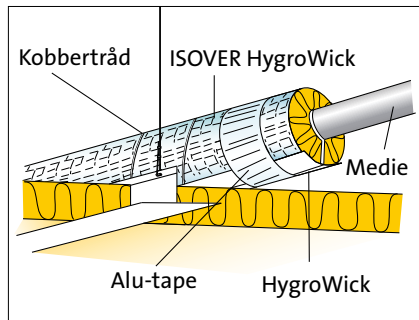

Fig. 4.1 Concealed pipes. HygroWick is installed traditionally with airtight joints. All joints are sealed with aluminium tape.

A neater finish

2. The aluminium foil on the insulation forms the final surface. Circumferential joints are sealed with aluminium tape. Longitudinal joints are sealed with special aluminium tape with punched holes.

3. A stiff PVC film such as Isogenopak, with punched holes, is used as the final surface. The holes are lined up with the wick.

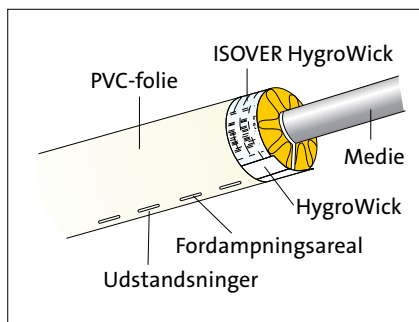

Fig. 4.2 Visible pipes. PVC film fitted with concealed joints. The moisture evaporates through punched holes in the film on the underside of the pipe

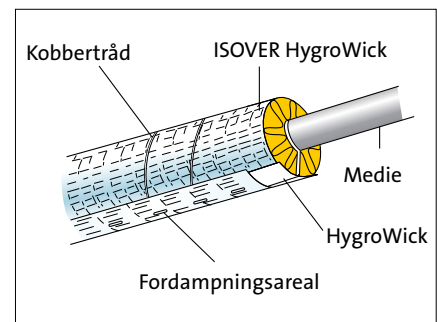

Fig. 4.3 Visible/ concealed pipes. The HygroWick wick is taped with special tape with an evaporation area. Circumferential joints are sealed with ordinary aluminium tape.

Finish without any holes

4. The final surface consists of a metal sheath that is seamed or riveted together. Joints in the sheath are open enough for there to be no need for punched holes.

5. The final surface consists of vapour permeable roll material without punched holes, for example, polyamide film or an HDPM fibre mat such as Tyvek.

6. The final surface consists of stiff PVC film without punched holes. The PVC film is relatively impermeable. For this reason, the HygroWick system transfers 100-200 times less water with this solution. This can, however, still be enough if no moisture enters through penetrations. This method therefore requires special details.

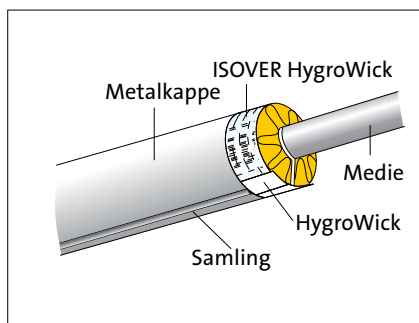

Fig. 4.5 Visible pipes. The metal sheath is fitted using seamed or riveted joints. The moisture evaporates through joints in the sheath.

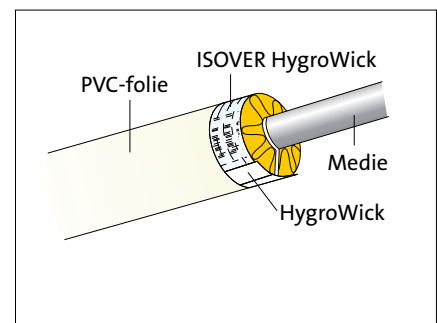

Fig. 4.4 Visible pipes. PVC film, polyamide film or HDPM membrane installed with concealed joints. The moisture evaporates through the film or membrane which has a relatively low resistance to diffusion.

Installation of HygroWick

Corrosion protection

The pipes must have corrosion protection to prevent corrosion. This must be in accordance with DS 454 class 2 or 3 depending on service conditions.

There are several types of paint on the market. It is important to follow the paint manufacturer's instructions, particularly with respect to the dry film thickness.

The use of cold asphalt or other slow drying protective films is not advised due to possible adhesion between the HygroWick wick and the protective coating.

Installation of the insulation

HygroWick is installed and tied with copper wire, such that the joint is tight and placed beneath the pipe on horizontal runs. On vertical pipes, the joints can be as desired.

The HygroWick wick/ evaporation area must never be painted over.

In the event of a painted surface being wanted, the wick/ evaporation area should be covered with masking tape, which must be removed immediately after painting.

For PVC film without holes

It is not practical to make completely air and watertight joints around meters, valves and other parts of the system that penetrate the sheath. Therefore, the PVC film solution without punched holes cannot be used here.

Instead, the transition between straight pipes, valves etc. must be sealed tight to the pipe, e.g. with Isogenopak end-caps, sealed against the pipe and glued tight to the external film.

Then the insulation immediately around the penetration can be installed in the traditional way with wire windings, and with a 5 cm wick of HygroWick projecting from the insulation.

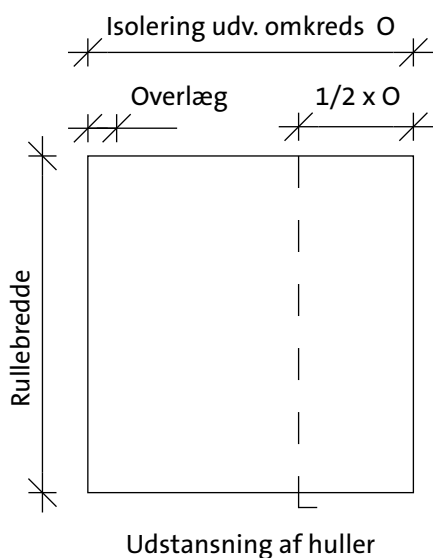

Fig. 5.1 Punched holes in the film or membrane, with joints on the top of the pipe. The joint in the termination may be placed as desired on the pipe. But the punched holes must always be located beneath the HygroWick evaporation area on the underside of the pipe.



Details

Pipe bends

Before installing the ISOVER, the bends are wrapped with HygroWick. The HygroWick strip is laid right out onto the straight pipework to ensure that moisture is transferred from the bend to the HygroWick wick on the straight runs. The shaping ISOVER Lamellar mat is installed and fixed with copper wire.

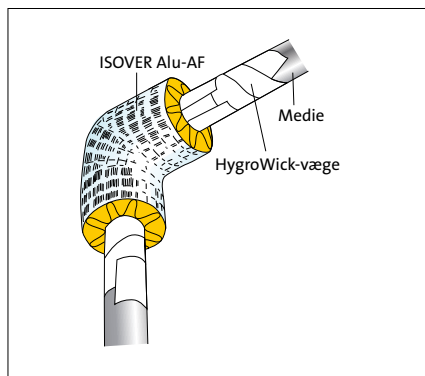

Fig. 6.1 Pipe bend.

Vertical pipes

Joints can be placed as desired on vertical pipes, but it is recommended that they be turned towards the wall. If the bottom of a vertical pipe ends with a bend and a short piece of horizontal pipe, an extra evaporation area should be installed

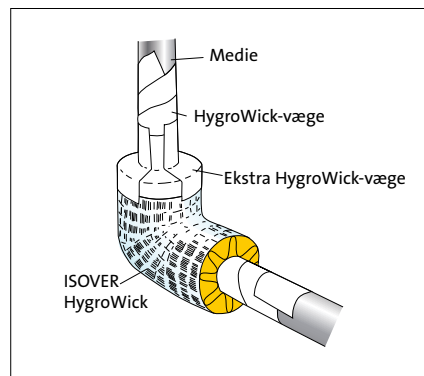

Fig. 6.2 Bend with extra evaporation area.

to avoid accumulation in the bend itself, see fig. 6.2.

If the vertical pipe ends in a stub, an extra evaporation area should be installed, see fig. 6.3.

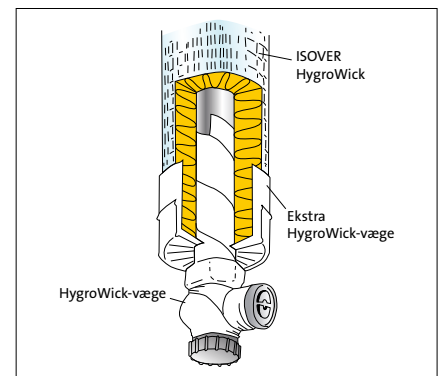

Fig. 6.3 Bend with extra evaporation area.

Valves and flanges

Small valves and couplings can be insulated with the same material and finish as the pipe itself.

Large valves and flanges must be insulated with ISOVER Lamellar mat fitted in a metal sheath. The pipe insulation itself must be terminated at a distance from flanges and valves that is no less than the length of the bolts.

Before installing the insulation, the flanges and valves are wound with HygroWick strip by the “mummy method”.

The HygroWick strip is applied all the way out to the regular pipes to ensure that condensation is transferred to the evaporation areas.

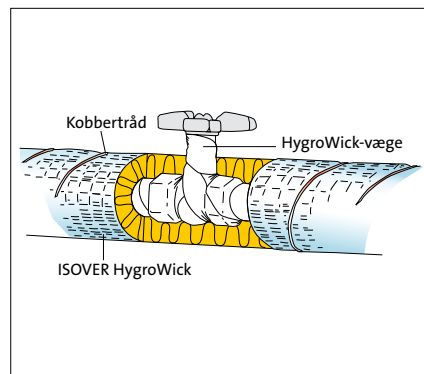

Fig. 6.4 Bend with extra evaporation area.

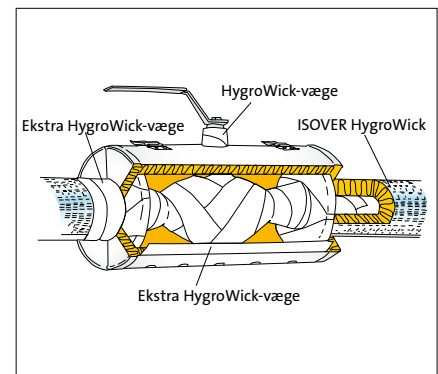

Fig. 6.4 Bend with extra evaporation area.

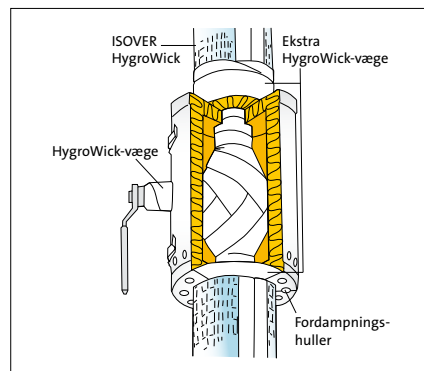

Fig. 6.5 Bend with extra evaporation area.

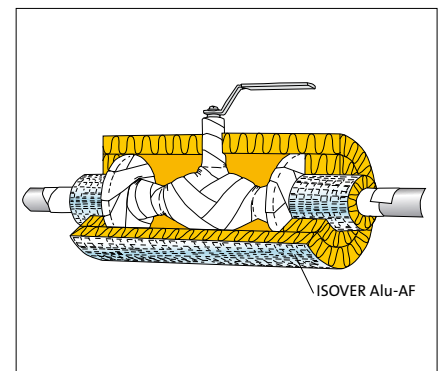

Fig. 6.6 Bend with extra evaporation area.

Penetrations

At penetrations, it is important to wrap the pipe in the wall and approx. 10 cm out from each face of the wall.

Then the piece is insulated in the thickness of the wall with an ordinary insulating mat or a HygroWick mat, in which case the evaporation area should be taped up to prevent moisture entering the wall, see fig. 7.1.

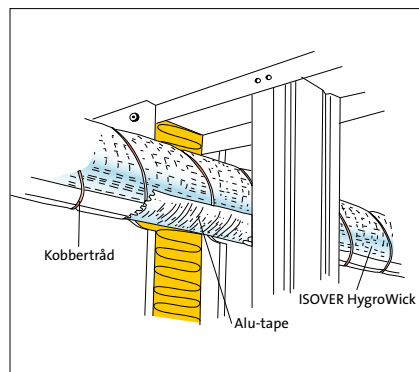

Fig. 7.1 Penetration

Horizontal terminations

Where a horizontal pipe terminates to a wall, cooling plant or similar, extra wick should be installed for a distance back on the outside of the insulation, see fig. 7.2.

Supports and stubs

At supports, stubs, thermometers and all items or fittings projecting beyond the insulation, these must be wrapped before the HygroWick is installed, leaving at least 5 cm of HygroWick wick outside the insulation.

For supports, always remember that the necessary thickness of insulation must also be applied on the outside of the support.

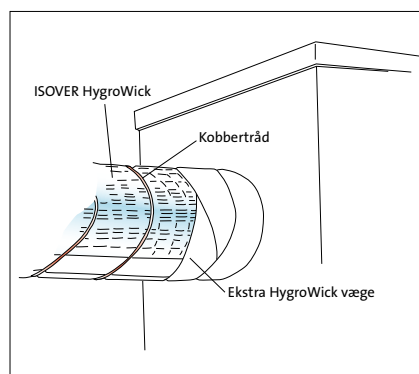

Fig. 7.2 Horizontal termination.

Space requirements

According to DS 1102, pipes to be insulated after erection must have a minimum distance of 50 mm to other pipes or building parts, which must be allowed for at the design stage.

In practice, at least 60 mm is desirable to allow for installation.

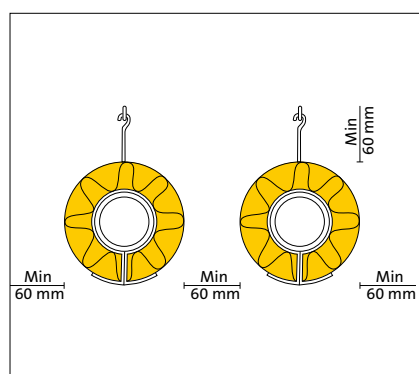

Fig. 7.3 Recommended minimum distances for pipe insulation

ISOVER
Det er lettere at isolere med ISOVER

Saint-Gobain Isover a/s
Østermarksvej 4
6580 Vamdrup
Telefon 72 17 17 27
Telefax 72 17 19 19
E-mail: isover@isover.dk
www.isover.dk